

USER ASSEMBLY GUIDE

**SINGLE & DOUBLE WIDTH
MOBILE ACCESS TOWERS**

**LIFT_{OFF}
TOWER**

PART OF THE T_{OFF} RANGE



Licence No.
KM 617169

LFI



THIS ASSEMBLY GUIDE IS INTENDED TO PROVIDE YOU WITH STEP-BY-STEP INSTRUCTIONS ON HOW TO ERECT YOUR MOBILE ACCESS TOWER WITH EASE AND SAFETY, USING THE 3T THROUGH THE TRAP METHOD.

You should read and understand all notes and diagrams, including the parts list for each height, before commencing assembly. Personnel should be qualified or competent to erect this tower. Please consult the PASMA's code of practice for full information on the use of Mobile Access Towers.

Remember to do a risk assessment of the area where the tower is to be used before commencing erection.

This instruction manual shall be available on the location of use of the mobile access and working tower.

This mobile access and working tower shall only be used according to this manual without any modification.

Mobile access and working towers must only be used in accordance with national regulations.

| CONTENTS | PAGE |
|-------------------------------|-------------|
| Description | 3 |
| Safety Notes & Fittings | 3 |
| Inspection Care & Maintenance | 5 |
| Components & Weights | 7 |
| Assembly | 8 |
| Dismantling | 15 |
| Configurations & Weights | 16 |
| Risk Assessment Form | 18 |

Manufactured to:
BS EN1004-1:2020
CLASS 3 8/12 XXXD

Licence No. KM 617169



Instruction Manual:
EN 1004-2 en x cz x es x fr x pl

DESCRIPTION, SAFETY NOTES & FITTINGS

DESCRIPTION

The TuFF ToWER is manufactured to BS EN1004-1:2020 CLASS 3 8/12 XXXD and KITEMARKED. The KITE MARK is the universal symbol that reassures the user that the product is certified to BSI stated standards

- + Instructions for erection and use to be followed carefully
- + A risk assessment should always be carried out before erecting your MAT (Mobile Access Tower)
- + You will find a standard risk assessment form at the back of this instruction manual
- + The TuFF ToWER has a maximum working platform height of 8.2 meters outdoors and 12.2 meters indoors
- + The maximum permissible load on the TuFF ToWER is 950kgs and evenly distributed on each platform is 275kgs. This must not be exceeded over the working height platforms, not including rest platforms
- + Maximum of 1 working platform per tower
- + Maximum of 2 people per working platform
- + Damaged or incorrect components shall not be used.

SAFETY NOTES

ERECTION & DISMANTLING - THE 3T(through the trap) METHOD

Towers should be erected following a safe method of work, there are two approved methods recommended by 'Prefabricated Access Suppliers & Manufacturers Association' (PASMA) in co-operation with the Health and Safety Executive (HSE) & the "working at height regulations 2005"

The method used for erecting and dismantling the TuFF ToWER tower is the 3T METHOD (through the trap).

This method ensures the operators erecting the tower position themselves in the trapdoor of the platform to add or remove horizontal guardrail braces for the level above the platform.

NEVER STAND ON AN UNGUARDED PLATFORM.

Before assembly or erection of this Mobile Access Tower (MAT) please ensure that:

- + A risk assessment has been done and all safety equipment is on site
- + The ground conditions will take the working loads of MAT as specified
- + Always check that the MAT is vertical, (Level, slope, uneven ground etc. if levelling is required make sure you adjust legs , in line with instructions (use spirit level)
- + Beware of (overhead) obstructions – live wires, electrical apparatus or moving parts of machinery or other
- + Wind conditions are within limits as specified (Refer to page 6)
- + Do not use boxes, ladders, or other devices on the platform to gain additional height
- + If in doubt DO NOT ERECT
- + Check that all components are on site and that they are in good working order before use (refer to the components and quantities shown at each stage). Auxiliary equipment and safety equipment (ropes, etc)
- + All platforms MUST have horizontal guardrails fitted
- + The tower should always be accessed from the inside using the ladder frames provided
- + Never climb up the outside
- + Do not use the guardrail braces as a rung or step
- + It is recommended that 2 persons erect this tower
- + The assembled tower should not be used as a means to enter or exit other structures, e.g. as a stair tower
- + Beware of horizontal forces (e.g., when using power tools on an adjacent structure), which could generate instability or overturning of the tower
- + Maximum distance between platforms is 2.25m, maximum distance to the first platform is 3.4m
- + Maximum horizontal force 20kgs
- + Mobile access and working towers are not designed to be sheeted
- + The tower height used should be appropriate for the working height, e.g. within 2 meters above the platform
- + User training courses cannot be a substitute for instruction manuals but only complement them
- + Only the original LFI components specified in the manual shall be used
- + Mobile access and working towers designed in accordance with BS EN 1004-1:2020 are not anchor points for personal fall arrest equipment
- + Working is only permitted on a platform with a complete side protection including guardrails and toe boards
- + Mobile access and working towers are not designed to be used as edge protection.

STABILISERS & BALLAST

Stabilisers or outriggers and ballast shall always be fitted when specified. When using the MAT externally stabilisers must be fitted. Should ballast be required, a platform should be positioned on the lowest rung and the weights should be firmly attached to it and evenly distributed. For advice on ballast contact your supplier.

LIFTING OF EQUIPMENT

- + Tools and other equipment should be hauled up by a person on the platform using rope or similar, through the trapdoor of the platform or within the tower footprint
- + Please see footprint guide on page 16
- + Safe working loads of platform and tower not to be exceeded.

MOVING THE TOWER AND LEAVING IT UNATTENDED

- + Adjust the stabilisers to provide ground clearance
- + Unlock the castor wheels
- + Move with manual force only, and only from the base
- + Beware of (overhead) obstructions – live wires, hanging apparatus or other objects
- + Do not move with people or material on the tower
- + Do not move the assembled MAT if wind speeds exceed a moderate breeze
Relock the castors and readjust the stabilisers once in the new position
- + When moving the tower over uneven or sloping ground remove all tools
- + Do not move the assembled tower if over 4 meters high
- + Recheck that the MAT is vertical or needs readjustment of legs before ascending (Using spirit level)
- + Mobile access and working towers shall only be moved on a flat and solid ground without obstacles and not on a slope of more than 10mm/1m

It is recommended that towers should be tied to a solid structure, when left unattended.

TIES

When ties are required, they should be in accordance with table 17 of BS 5973:1990 and table 24 of BS 5975:1982. Always tie to a solid structure.

The tie frequency should be at 4 meter intervals or less vertically.

FITTING TOE-BOARDS

1 piece folding toe board: fold out over platform making sure location angle rests fits securely on side of platform.

LIFTING OF INDIVIDUAL TOWER COMPONENTS

Raising and lowering components, tools and/or materials by rope should be conducted within the tower base (i.e. within the area bounded by the stabilisers). Ensure that the safe working load of the supporting decks and the tower structure is not exceeded.

Check for environmental changes before every use. (ie: all weather conditions) Refer to next page for wind effects.

CHECK LIST, INSPECTION CARE & MAINTENANCE FOR MOBILE ACCESS TOWERS

DESCRIPTION

- + All components should be inspected before use to ensure that they are not damaged or broken, particularly the welds
- + ANY damage to ANY part particularly tubular members, castors, platform decking MUST be replaced
- + Adjustable leg threads should be cleaned and lightly oiled
- + All locking claws should be cleaned, and the locking mechanism checked for operation
- + When storing your MAT, please ensure that all components are neatly stored and not left lying around where they could be stood on or damaged
- + When transporting the MAT always tie the components down so that they do not move around and get damaged
- + Should the tower be left unattended it should be tied to a suitable structure and on reuse ALWAYS check that the tower is vertical and safe before ascending correct and complete structure
- + The MAT is not designed to be lifted or suspended as a complete structure
- + Always keep this instruction manual safe
- + Broken, damaged or incorrect components must never be used. The equipment shall be quarantined and assessed for replacement repair or destruction.

WIND EFFECTS

- + Beware of high, gusty, or moderate breeze conditions in exposed areas. It is recommended that in wind speeds over a Moderate Breeze (see Beaufort Scale below) that work on the tower is stopped and reassessed. If the wind becomes a Strong Breeze, (see Beaufort Scale below) the tower should be tied to a rigid structure. If the wind is likely to reach Gale Force (see Beaufort Scale below) or over, work should be stopped, and the tower should be dismantled.
- + Beware of tunnelling effect caused by open ended buildings, uncladded buildings and building corners.

| Wind | Beaufort Scale 10m above ground | Force | Speed (mph) (kn) | |
|-----------------|---|-------|---------------------|-------|
| Moderate Breeze | Raises dust and loose paper, small branches move | 4 | 13-18 | 11-16 |
| Strong Breeze | Large branches in motion, telegraph wires whistle | 6 | 25-31 | 22-27 |
| Gale Force | Walking is difficult, twigs break off trees | 8 | 39-46 | 34-40 |

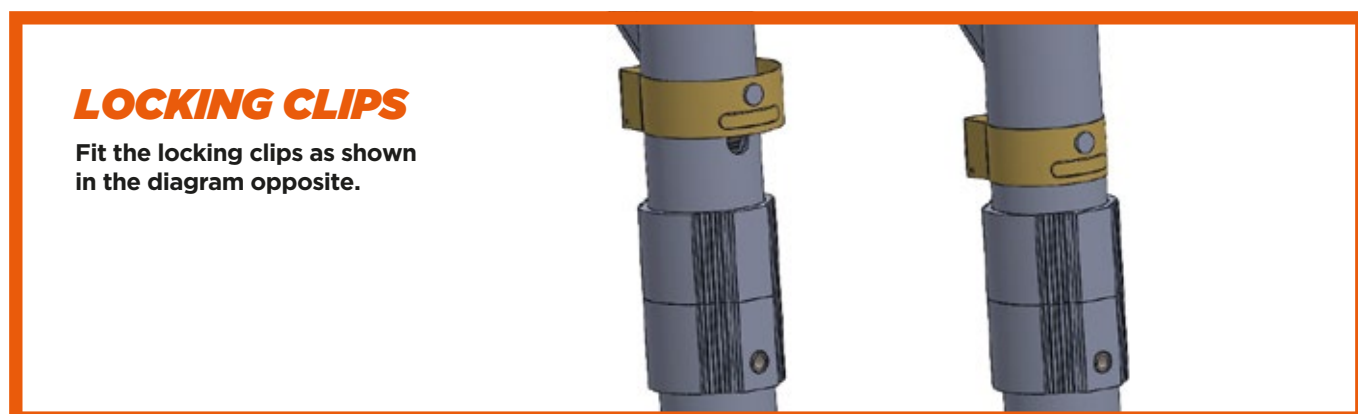

LOCKING CASTORS

Castor wheels should be pointed outwards at approximately 45 degrees and locks engaged as shown opposite.

FITTING STABILISERS

Attach a stabiliser to each corner of the tower at approximately 45 degrees for maximum stability and attach the clamps where indicated. On the S2 stabiliser use the telescopic leg for adjustment on uneven ground. Make sure that all stabilisers are firmly in contact with the ground when using the structure.

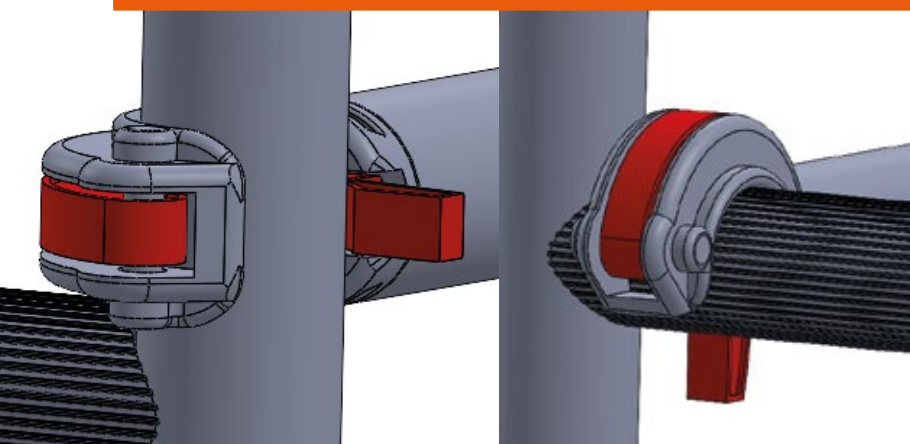
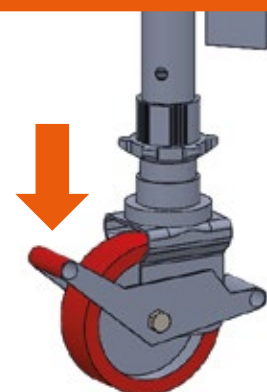

CORRECT FITTING OF HORIZONTAL BRACING

THE CORRECT FITTING OF HORIZONTAL BRACING IS IMPORTANT.

The diagrams opposite illustrate the CORRECT brace positions.

REMEMBER: Always fit braces DOWNWARD or from the inside facing OUTWARD - BUT NEVER INWARD

BRACE CLAMP LOCKING

Ensure that the brace clamp is locked as shown. Always make sure the brace is not clamped too close to the weld as indicated by the arrow on the drawing on the right.

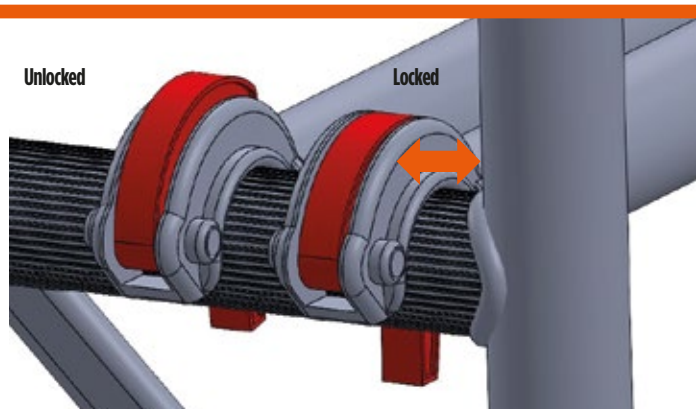

FITTING ADJUSTABLE LEGS

Take the adjustable leg assembly complete with its castors, make sure that all the adjusting nuts are positioned down at the castor and slide them into the vertical tube, turn the base unit the right way up and with the aid of a spirit level placed on the platform, the adjusting nuts can be used to level the structure. (and not to gain additional height).



IDENTIFYING COMPONENTS & THEIR WEIGHTS

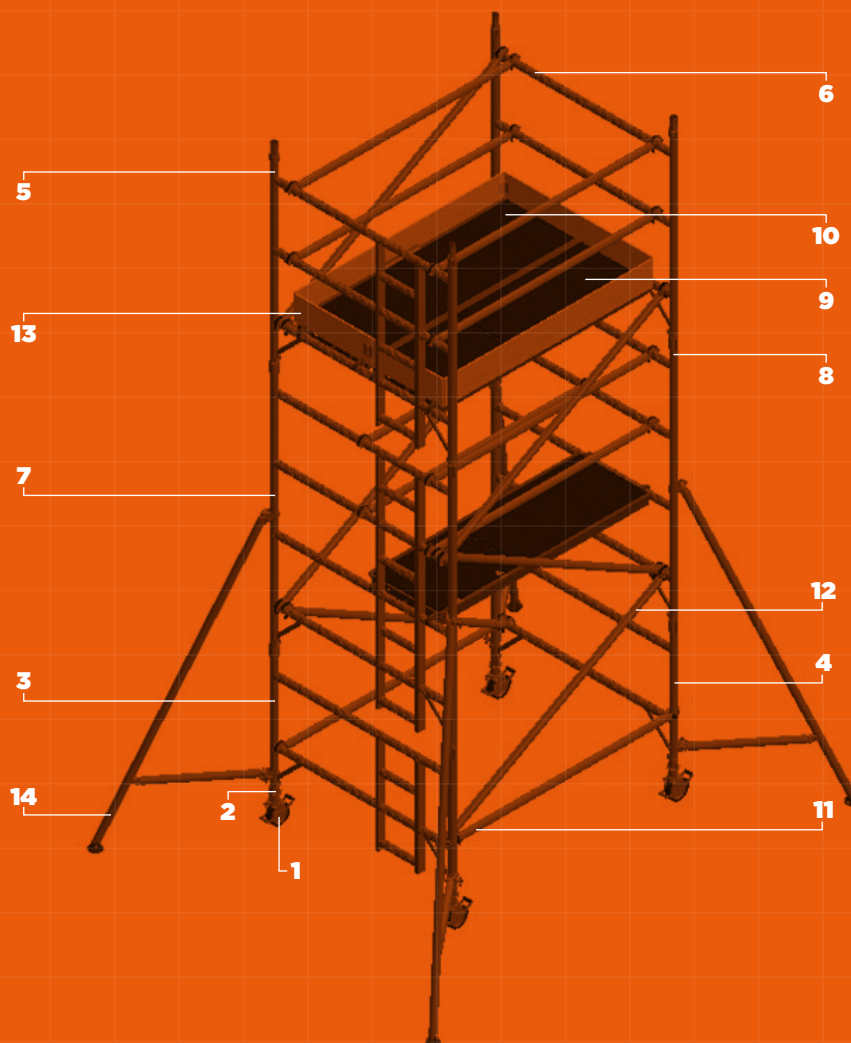

NOTE: When building structures over 4.2m remove platform and 4 horizontal braces from platform height at 2.2m and use to complete structure.

TOWER COMPONENTS & APPROX. WEIGHTS

| Item | Description | Weight (Kg) | Item | Description | Weight (Kg) |
|------|----------------------|-------------|------|------------------------|-------------|
| 1 | 150mm Locking Caster | 3.4 | 9 | 1.8m Trapdoor Platform | 12.7 |
| 2 | Adjustable Leg 500mm | 1.1 | 10 | 1.8m Fixed Platform | 11.8 |
| 3 | 1m Ladder Frame | 5.4 | 11 | 1.8m Horizontal Brace | 2.1 |
| 4 | 1m Span Frame | 4 | 12 | 2.1m Diagonal Brace | 2.2 |
| 5 | 1.5m Ladder Frame | 8 | 13 | Complete Toe Board Set | 8 |
| 6 | 1.5m Span Frame | 5.6 | 14 | S1 Stabiliser | 4.1 |
| 7 | 2m Ladder Frame | 10.4 | 15 | S2 Stabiliser | 5.9 |
| 8 | 2m Span Frame | 7.1 | | | |

ASSEMBLY PROCEDURE

LFI recommends a minimum of two people are required for the assembly of the LFI TuFF ToWER. Only climb the tower from the inside using the ladder section.

NOTE

Never place the platform on the guardrail frame. Always climb from the inside of the frame – never the outside. When working on the platform never overreach. The end frames should provide a firm hand hold.

| Platform Heights (m) | Frame at Base | Frame at Top |
|--------------------------------|---------------|--------------|
| 1.2, 3.2, 5.2, 7.2, 9.2, 11.2 | 4 Rung | 4 Rung |
| 1.7, 3.7, 5.7, 7.7, 9.7, 11.7 | 2 Rung | 3 Rung |
| 2.2, 4.2, 6.2, 8.2, 10.2, 12.2 | 2 Rung | 4 Rung |
| 2.7, 4.7, 6.7, 8.7, 10.7 | 3 Rung | 4 Rung |

+ 1.0 STEP

Insert adjustable leg assembly (with castors or base plates) into the base of ladder frame, repeat this with the span frame. Lock all castor wheels.

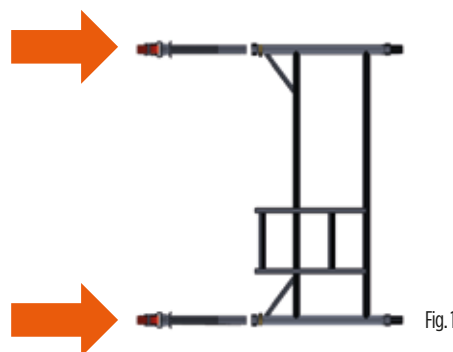

+ 2.0 STEP

Attach one horizontal brace to the bottom rung of the span frame, claws facing downwards. This frame will now be self-supporting.



+ 3.0 STEP

Position the ladder frame as shown. Connect the other end of the horizontal brace to the ladder frame. Now connect the frames using a second horizontal brace on the opposite side, attach from the inside of the frame just above the bottom rung, claws facing outwards, this will square the tower. Check tower is vertical using spirit level.

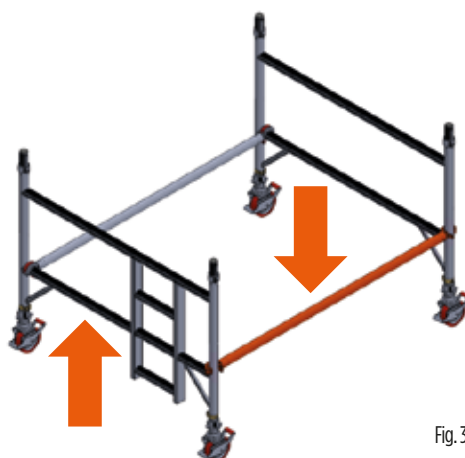

+ 4.0 STEP

Insert 4 rung frames to correspond with the 2 rung frames (fig. 4) and lock the locking clips (refer to page 6). Attach diagonal braces on both sides from the 1st rung to the 3rd rung of the structure, in opposing directions. Place a trap door platform on the 1st rung and a trap door platform on the 4th rung, both on the ladder side of the structure. Attach wind locks.



Fig. 4

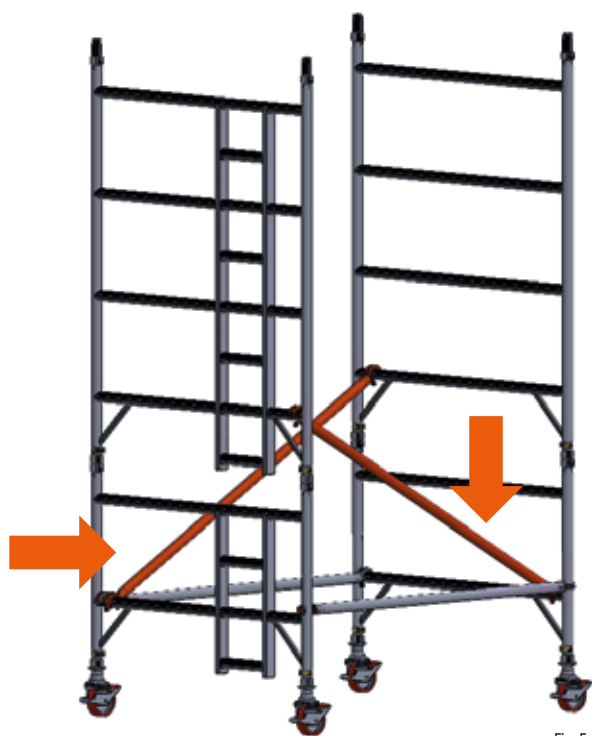

Fig. 5



Fig. 6

+ 5.0 STEP

Attach stabilisers as required for working height (see table page 16).
Climb the ladder and from a protected through the trapdoor position, attach horizontal guardrail braces to the 5th and then 6th rungs, on both sides of the platform.
Never climb onto a platform that is not fully guarded. Guardrails should be 1 and 2 rungs above platforms in all cases.

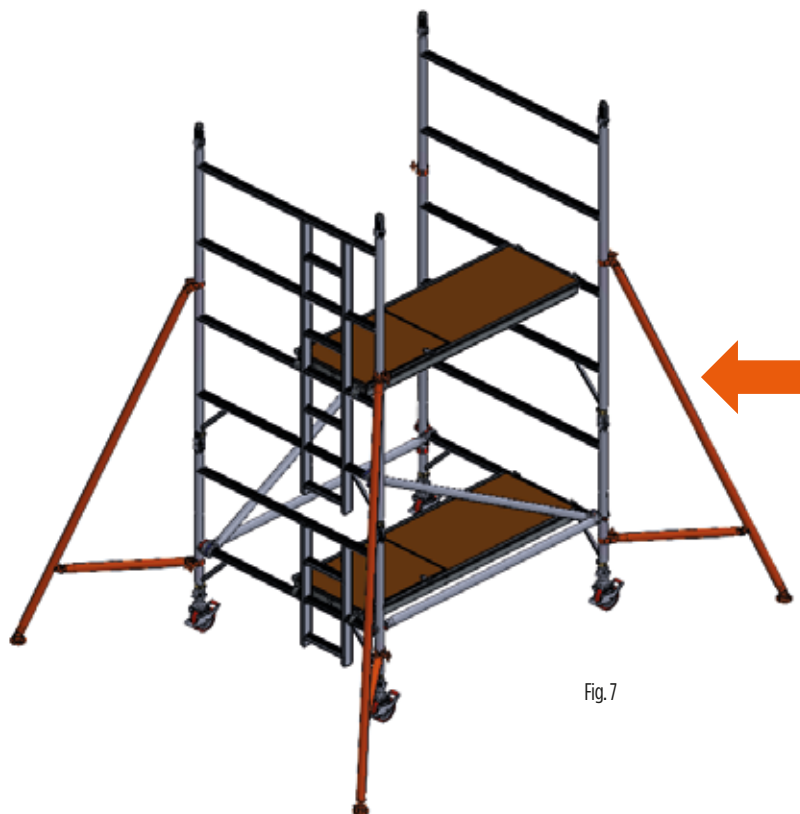

Fig. 7



Fig. 8

+ 6.0 STEP

Attach 2nd pair of diagonal braces following on from the previous ones. Attach the next 4 rung frames and lock clips (as per fig. 9).

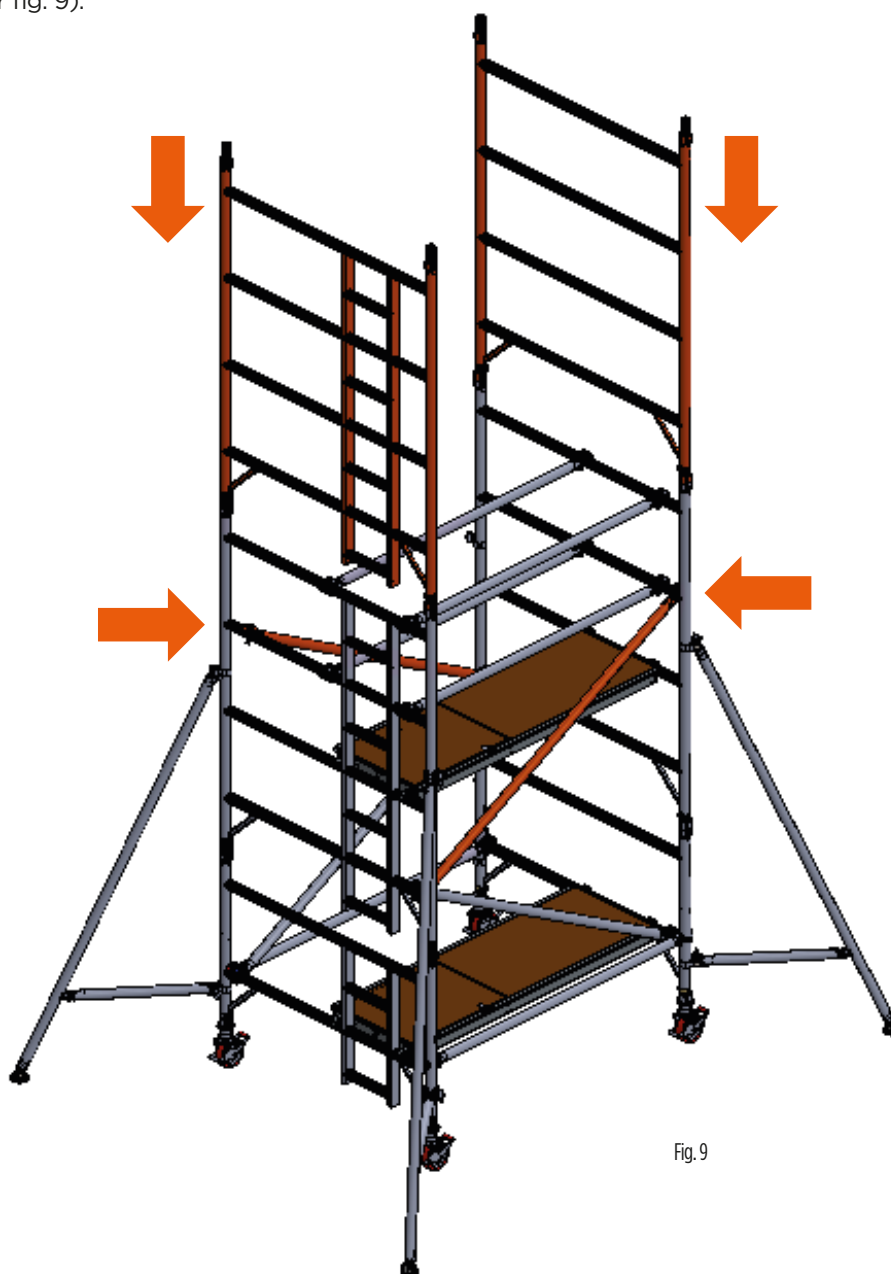

Fig. 9

+ 7.0 STEP

If completing the tower at this height (4m), continue with step 8. When building beyond this level, repeat steps 4, 5 and 6 until desired level is achieved, then complete the tower with steps 8 and 9. Reuse the trap door platform from 1st rung on the final height.



Fig. 10



Fig. 11



Fig. 12

+ 8.0 STEP

Fit the final diagonal braces as shown. This stage will provide a platform height of 4m. Attach diagonal braces as per fig. 7. The 1st rung trap door platform should be moved up to the 8th rung, the fixed platform can now be fitted alongside it.

LOCK WIND LOCKS.

Climb up the ladder and from a protected 'through the trapdoor' position, fit horizontal guardrail braces to the 9th and then the 10th rungs on both sides of the tower. Complete the tower assembly by following Step 9.



Fig. 13

+ 9.0 STEP

Fit toe boards to all working platforms (see instructions on page 4 & 5).

NOTE:

Maximum distance between platforms should not exceed 2.25m.

Maximum distance to first platform should not exceed 3.4m.

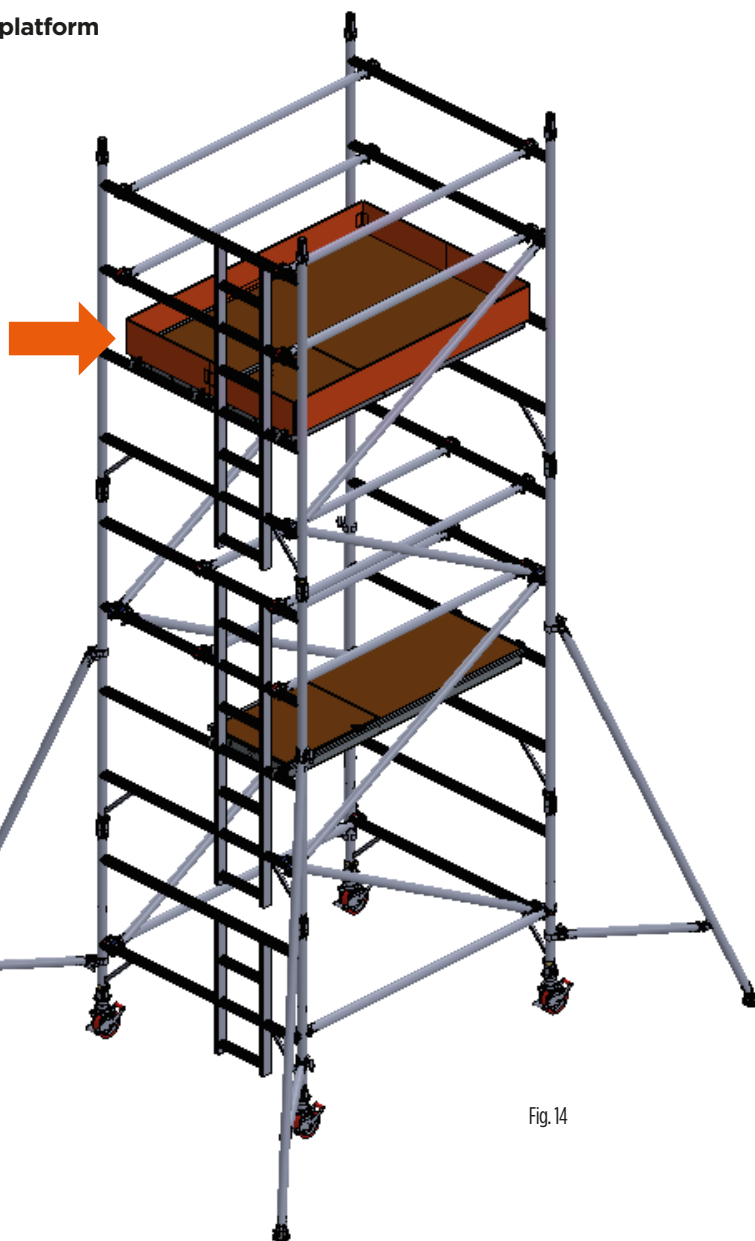

Fig. 14

DISMANTLING

The dismantling procedure should follow the assembly steps in reverse order, take particular attention about the removal of guardrails and platforms.

You should ensure that you are standing in a safe position and always protected by guardrails NEVER remove diagonal braces or stabilisers prematurely.

After removing the toe-boards the operator disengages the horizontal guardrail brace clamps furthest from the trap door, horizontal guardrail braces are then removed with the operator positioned through the trap door before descending to the lower level, from where the upper platform and extensions/guardrail frames can be removed.

NOTE: DO NOT OVER-REACH and NEVER DROP COMPONENTS when dismantling always lower them to the ground.

STABILISERS

Attach one stabiliser to each corner of tower at approx. 45 degrees. The bottom clamp should be fitted as low as possible, refer to the diagram opposite. Ensure that all four rubber feet are in contact with the ground and that the clamps are secured. Position stabilisers as shown in the diagrams.

When using the S2 stabilisers, always extend the telescopic legs to their maximum position and lock into position with the interlock clip.

When moving the tower lock each telescopic leg just clear of the ground, unlock castors ensuring area is firm and clear of all obstructions both on the ground and above.

After moving check all castors are firmly on the ground and locked, and that the tower is vertical. Re-position stabilisers as above.

STABILISERS S1

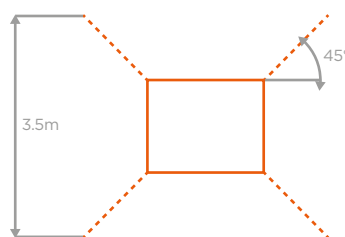
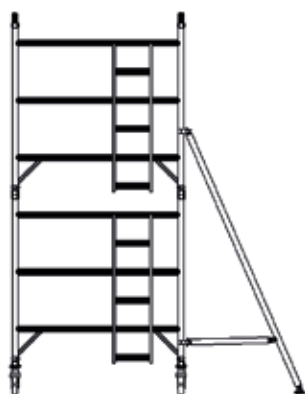

Static Stabiliser maximum platform height

| | |
|--------------|-------|
| Single width | 0.85m |
| Indoors | 8.2m |
| Outdoors | 8.2m |
| Double width | 1.45m |
| Indoors | 8.2m |
| Outdoors | 8.2m |

STABILISERS S2

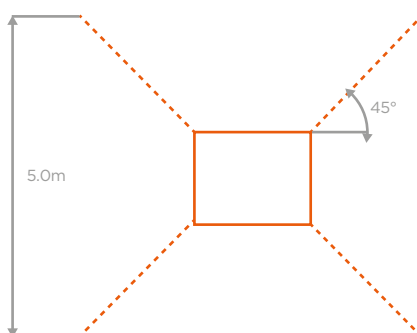
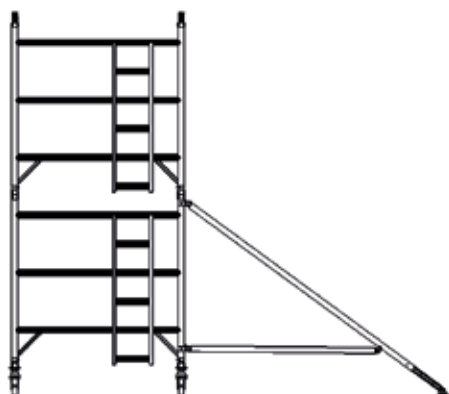

Telescopic Stabiliser maximum platform height

| | |
|--------------|------------|
| Single width | 0.85m |
| Indoors | 8.7m-12.2m |
| Double width | 1.45m |
| Indoors | 8.7m-12.2m |

INTERNAL & EXTERNAL USE 0.85M SINGLE WIDTH TOWER

CONFIGURATIONS TO BS EN1004-1:2020 FOR 1.8M OR 2.5M LENGTHS.

| WORKING HEIGHT PLATFORM HEIGHT | INTERNAL & EXTERNAL USE | | | | | | | | | | | | | | INTERNAL USE ONLY | | | | | | | | | |
|-----------------------------------|-------------------------|------------|------------|------------|------------|------------|------------|------------|------------|------------|------------|------------|------------|------------|-------------------|-------------|-------------|-------------|--------------|--------------|--------------|--------------|--------------|-------|
| | 3.2 1.2 | 3.7 1.7 | 4.2 2.2 | 4.7 2.7 | 5.2 3.2 | 5.7 3.7 | 6.2 4.2 | 6.7 4.7 | 7.2 5.2 | 7.7 5.7 | 8.2 6.2 | 8.7 6.7 | 9.2 7.2 | 9.7 7.7 | 10.2 8.2 | 10.7 8.7 | 11.2 9.2 | 11.7 9.7 | 12.2 10.2 | 12.7 10.7 | 13.2 11.2 | 13.7 11.7 | 14.2 12.2 | |
| DESCRIPTION | | | | | | | | | | | | | | | | | | | | | | | | |
| Castor | 4 | 4 | 4 | 4 | 4 | 4 | 4 | 4 | 4 | 4 | 4 | 4 | 4 | 4 | 4 | 4 | 4 | 4 | 4 | 4 | 4 | 4 | 4 | 4 |
| Adjustable Leg Unit | 4 | 4 | 4 | 4 | 4 | 4 | 4 | 4 | 4 | 4 | 4 | 4 | 4 | 4 | 4 | 4 | 4 | 4 | 4 | 4 | 4 | 4 | 4 | 4 |
| 0.85 x 2 Rung Ladder Frame | - | 1 | 1 | - | - | 1 | 1 | - | - | 1 | 1 | - | - | 1 | 1 | - | - | 1 | 1 | - | - | 1 | 1 | - |
| 0.85 x 2 Rung Span Frame | - | 1 | 1 | - | - | 1 | 1 | - | - | 1 | 1 | - | - | 1 | 1 | - | - | 1 | 1 | - | - | 1 | 1 | - |
| 0.85 x 3 Rung Ladder Frame | - | 1 | - | 1 | - | 1 | - | 1 | - | 1 | - | 1 | - | 1 | - | 1 | - | 1 | - | 1 | - | 1 | - | - |
| 0.85 x 3 Rung Span Frame | - | 1 | - | 1 | - | 1 | - | 1 | - | 1 | - | 1 | - | 1 | - | 1 | - | 1 | - | 1 | - | 1 | - | - |
| 0.85 x 4 Rung Ladder Frame | 1 | - | 1 | 1 | 2 | 1 | 2 | 2 | 3 | 2 | 3 | 3 | 4 | 3 | 4 | 4 | 5 | 4 | 5 | 5 | 6 | 5 | 6 | 6 |
| 0.85 x 4 Rung Span Frame | 1 | - | 1 | 1 | 2 | 1 | 2 | 2 | 3 | 2 | 3 | 3 | 4 | 3 | 4 | 4 | 5 | 4 | 5 | 5 | 6 | 5 | 6 | 6 |
| 1.8 or 2.5 Fixed Platform | - | - | - | - | - | - | - | - | - | - | - | - | - | - | - | - | - | - | - | - | - | - | - | - |
| 1.8 or 2.5 Trap Door Platform | 1 | 1 | 1 | 2 | 2 | 2 | 2 | 2 | 3 | 3 | 3 | 3 | 4 | 4 | 4 | 4 | 5 | 5 | 5 | 5 | 6 | 6 | 6 | 6 |
| 1.8 or 2.5 Horizontal Brace | 6 | 6 | 6 | 6 | 10 | 10 | 10 | 10 | 14 | 14 | 14 | 14 | 18 | 18 | 18 | 18 | 22 | 22 | 22 | 22 | 26 | 26 | 26 | 26 |
| 2.1 or 2.7 Diagonal Brace | 2 | 3 | 3 | 4 | 5 | 6 | 7 | 8 | 9 | 10 | 11 | 12 | 13 | 14 | 15 | 16 | 17 | 18 | 19 | 20 | 21 | 22 | 23 | 23 |
| Folding Toe Board Set | 1 | 1 | 1 | 1 | 1 | 1 | 1 | 1 | 1 | 1 | 1 | 1 | 1 | 1 | 1 | 1 | 1 | 1 | 1 | 1 | 1 | 1 | 1 | 1 |
| Instruction Manual | 1 | 1 | 1 | 1 | 1 | 1 | 1 | 1 | 1 | 1 | 1 | 1 | 1 | 1 | 1 | 1 | 1 | 1 | 1 | 1 | 1 | 1 | 1 | 1 |
| S1 Stabiliser | - | - | 4 | 4 | 4 | 4 | 4 | 4 | 4 | 4 | 4 | 4 | 4 | 4 | 4 | - | - | - | - | - | - | - | - | - |
| S2 Stabiliser | - | - | - | - | - | - | - | - | - | - | - | - | - | - | - | 4 | 4 | 4 | 4 | 4 | 4 | 4 | 4 | 4 |
| Approx. 1.8 tower shelf weight | 74.2 | 81.2 | 101.4 | 121.5 | 136.8 | 143.8 | 149.8 | 158.1 | 185.2 | 192.2 | 198.2 | 206.5 | 233.6 | 240.6 | 246.6 | 262.1 | 289.2 | 296.2 | 302.2 | 310.5 | 337.6 | 344.6 | 350.6 | 350.6 |
| Approx. 2.5 tower shelf weight | 81.9 | 89.1 | 109.3 | 133.8 | 149.5 | 156.7 | 162.9 | 171.4 | 203.1 | 210.3 | 216.5 | 225 | 256.7 | 263.9 | 270.1 | 285.8 | 317.5 | 324.7 | 330.9 | 339.4 | 371.1 | 378.3 | 384.5 | 384.5 |

All dimensions in metres. All weights in kg.

INTERNAL & EXTERNAL USE 1.455M DOUBLE WIDTH TOWER

CONFIGURATIONS TO BS EN1004-1:2020 FOR 1.8M OR 2.5M LENGTHS.

| WORKING HEIGHT PLATFORM HEIGHT | INTERNAL & EXTERNAL USE | | | | | | | | | | | | | | INTERNAL USE ONLY | | | | | | | | |
|-----------------------------------|-------------------------|------------|------------|------------|------------|------------|------------|------------|------------|------------|------------|------------|------------|------------|-------------------|-------------|-------------|-------------|--------------|--------------|--------------|--------------|--------------|
| | 3.2 1.2 | 3.7 1.7 | 4.2 2.2 | 4.7 2.7 | 5.2 3.2 | 5.7 3.7 | 6.2 4.2 | 6.7 4.7 | 7.2 5.2 | 7.7 5.7 | 8.2 6.2 | 8.7 6.7 | 9.2 7.2 | 9.7 7.7 | 10.2 8.2 | 10.7 8.7 | 11.2 9.2 | 11.7 9.7 | 12.2 10.2 | 12.7 10.7 | 13.2 11.2 | 13.7 11.7 | 14.2 12.2 |
| DESCRIPTION | | | | | | | | | | | | | | | | | | | | | | | |
| Castor | 4 | 4 | 4 | 4 | 4 | 4 | 4 | 4 | 4 | 4 | 4 | 4 | 4 | 4 | 4 | 4 | 4 | 4 | 4 | 4 | 4 | 4 | 4 |
| Adjustable Leg Unit | 4 | 4 | 4 | 4 | 4 | 4 | 4 | 4 | 4 | 4 | 4 | 4 | 4 | 4 | 4 | 4 | 4 | 4 | 4 | 4 | 4 | 4 | 4 |
| 1.45 x 2 Rung Ladder Frame | - | 1 | 1 | - | - | 1 | 1 | - | - | 1 | 1 | - | - | 1 | 1 | - | - | 1 | 1 | - | - | 1 | 1 |
| 1.45 x 2 Rung Span Frame | - | 1 | 1 | - | - | 1 | 1 | - | - | 1 | 1 | - | - | 1 | 1 | - | - | 1 | 1 | - | - | 1 | 1 |
| 1.45 x 3 Rung Ladder Frame | - | 1 | - | 1 | - | 1 | - | 1 | - | 1 | - | 1 | - | 1 | - | 1 | - | 1 | - | 1 | - | 1 | - |
| 1.45 x 3 Rung Span Frame | - | 1 | - | 1 | - | 1 | - | 1 | - | 1 | - | 1 | - | 1 | - | 1 | - | 1 | - | 1 | - | 1 | - |
| 1.45 x 4 Rung Ladder Frame | 1 | - | 1 | 1 | 2 | 1 | 2 | 2 | 3 | 2 | 3 | 3 | 4 | 3 | 4 | 4 | 5 | 4 | 5 | 5 | 6 | 5 | 6 |
| 1.45 x 4 Rung Span Frame | 1 | - | 1 | 1 | 2 | 1 | 2 | 2 | 3 | 2 | 3 | 3 | 4 | 3 | 4 | 4 | 5 | 4 | 5 | 5 | 6 | 5 | 6 |
| 1.8 or 2.5m Fixed Platform | 1 | 1 | 1 | 1 | 1 | 1 | 1 | 1 | 1 | 1 | 1 | 1 | 1 | 1 | 1 | 1 | 1 | 1 | 1 | 1 | 1 | 1 | 1 |
| 1.8 or 2.5m Trap Door Platform | 1 | 1 | 1 | 1 | 2 | 2 | 2 | 2 | 3 | 3 | 3 | 3 | 4 | 4 | 4 | 4 | 5 | 5 | 5 | 5 | 6 | 6 | 6 |
| 1.8 or 2.5m Horizontal Brace | 6 | 6 | 6 | 6 | 10 | 10 | 10 | 10 | 14 | 14 | 14 | 14 | 18 | 18 | 18 | 18 | 22 | 22 | 22 | 22 | 26 | 26 | 26 |
| 2.1 or 2.7 Diagonal Brace | 2 | 3 | 3 | 4 | 5 | 6 | 7 | 8 | 9 | 10 | 11 | 12 | 13 | 14 | 15 | 16 | 17 | 18 | 19 | 20 | 21 | 22 | 23 |
| Folding Toe Board Set | 1 | 1 | 1 | 1 | 1 | 1 | 1 | 1 | 1 | 1 | 1 | 1 | 1 | 1 | 1 | 1 | 1 | 1 | 1 | 1 | 1 | 1 | 1 |
| Instruction Manual | 1 | 1 | 1 | 1 | 1 | 1 | 1 | 1 | 1 | 1 | 1 | 1 | 1 | 1 | 1 | 1 | 1 | 1 | 1 | 1 | 1 | 1 | 1 |
| S1 Stabiliser | - | - | 4 | 4 | 4 | 4 | 4 | 4 | 4 | 4 | 4 | 4 | 4 | 4 | 4 | - | - | - | - | - | - | - | - |
| S2 Stabiliser | - | - | - | - | - | - | - | - | - | - | - | - | - | - | - | 4 | 4 | 4 | 4 | 4 | 4 | 4 | 4 |
| Approx. 1.8 tower shelf weight | 85 | 92.7 | 113 | 119.4 | 146.6 | 154.3 | 160.4 | 116.8 | 194 | 201.7 | 207.8 | 214.2 | 241.4 | 249.1 | 255.2 | 268.8 | 296 | 303.7 | 309.8 | 316.2 | 343.4 | 351.1 | 357.2 |
| Approx. 2.5 tower shelf weight | 97.4 | 105.3 | 125.6 | 132.2 | 164 | 171.9 | 178.2 | 184.8 | 216.6 | 224.5 | 230.8 | 237.4 | 269.2 | 277.1 | 283.4 | 297.2 | 329 | 336.9 | 343.2 | 349.8 | 381.6 | 389.5 | 395.8 |

All dimensions in metres. All weights in kg.

RISK ASSESSMENT COMPLETION FORM

Inspector _____ Date & time _____

Location & Site _____ Inspection No. _____

Main activity/situation _____ Signature _____

NOTES

A Personnel at Risk

- Employee
- Contractor
- Public

B Severity

- Negligible
- Minor injury
- Serious injury
- Major injury

C Probability

- Impossible
- Improbable
- Remote
- Occasional
- Probable
- Frequent

| INSPECTION NO. | ACTIVITY / LOCATION MATERIALS / TOOLS ETC. | HAZARDS IDENTIFIED | A | B | C | RISK RATING (BxC) | SAFETY EQUIPMENT TO BE USED | B | C | RISK RATING (BxC) | ACTION BY |
|----------------|---|-----------------------|---|---|---|----------------------|--------------------------------|---|---|----------------------|-----------|
| | | | | | | | | | | | |
| | | | | | | | | | | | |
| | | | | | | | | | | | |
| | | | | | | | | | | | |

RISK VALUE KEY

1-4 ACCEPTABLE. 5-9 **MEDIUM:** Investigate and where practicable reduce the risk. **10-14 HIGH:** Action must be taken to reduce risk.
15-24 VERY HIGH: Risk is too high to start work or continue, work must be stopped.



SUPPLIED BY:

**LFI - Ladder & Fencing Industries
(Newent) Ltd.**

Horsefair Lane, Newent,
Gloucestershire GL18 1RP

Email: info@lfi-ladders.co.uk

 britishladders.co.uk     

